

Chapter 2

Characteristics of adverse drug reactions¹

Intuitively, the ADR² (adverse drug reaction) is associated with that part of a drug action or treatment that physicians and patients want to avoid [Anonymous 1987]. Drugs are administered for the purposes of curative or palliative treatment. Scientists seldom think of ADRs as an aspect of drugs that might contribute directly to the process of drug design and development, nor do they connect this aspect indirectly to the development of (patho)physiological, or pharmacological knowledge. However, some exceptions exist. Examples (mostly anecdotal) can be found in the medical literature of ADRs that were used to obtain a completely different therapeutic effect of the same drug for another disease(s). These exceptions are often referred to as serendipity in clinical drug development [Roberts 1989, Anonymous 1996].

However, we will argue that ADRs can play an important role in the medical and pharmaceutical sciences in several ways. In this chapter we will start with the situation that can be referred to as *æstablished knowledge* as represented in text books and review articles. We will then make this situation gradually more complex and introduce more levels of analysis. The aim of the studies in this chapter is to identify a series of arguments for the hypothesis that ADRs can be a potential source for drug innovation.

Medical therapy & Adverse Drug Reactions

In medical practice a drug is often given to a patient in order to prevent an anticipated disease or to treat a manifest disease. Two types of effects can be expected after the administration of a drug to a patient, as shown in Figure 1. The first type of effect is the intended effect: the reason why the drug was given to the patient. The second type of effect is the unintended, unwanted or noxious effect. These effects are referred to as adverse drug reactions, or ADRs.

Almost every drug has its own set of therapeutic and adverse effects. The balance between the two types of effects, resulting in a risk-benefit ratio, is a major element in assessing the usefulness of the drug for medical practice. In the case of a very severe or fatal disease, more serious adverse drug reactions are acceptable in principle than in the case of a rather harmless disease. For example, the severe adverse drug reactions of typical anticancer drugs would never be accepted for simple problems like constipation or cough. Although drugs with no adverse drug reactions remain to be developed, it should be noted that the range and severity of ADRs differs from one drug to another.

Drugs often have their own specific profile of adverse drug reactions: just as the therapeutic effect profile of a drug is, to some extent, unique for each drug, so is the

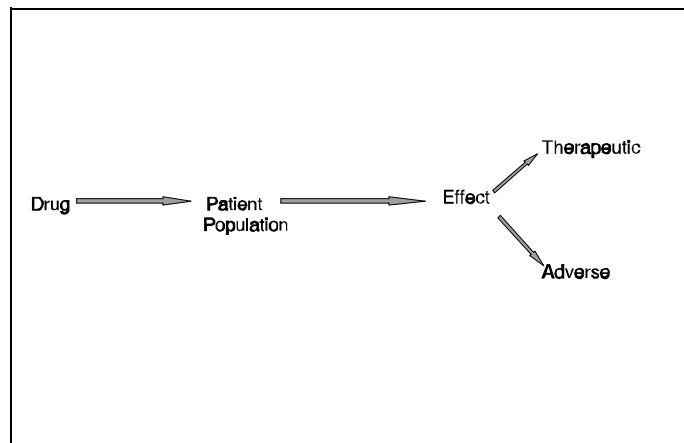

Figure 1: Effects of a drug

¹The term innovation is here used to comprehend the process of drug discovery and drug design.

The definition used by Spilker in 'multinational drug companies' is:

'(1) something new or different and the (2) introduction of new things and methods.'

Although the output of innovation in drug discovery and development is often measured in terms of new drug, some exceptions are given.

Included in the concept of *ænnovations* are the discovery of new uses for old drugs and novel approaches for marketing and producing the drug. Cultural differences can influence the interpretation of *ænnovation*. All things that can contribute to the discovery of new drugs, such as new routes of chemical synthesis, are regarded here as innovation.

²ADR (adverse drug reactions) will be used as the general term referring to those effects of a drug that are not therapeutic. The terms used by authors of scientific literature will be written in full (for example side effect, adverse event, adverse drug reaction, etc).

profile of its ADRs³. Some ADRs are observed across a wide variety of drugs, irrespective of their therapeutic application: allergic reactions are an example. When a group of drugs have very similar therapeutic effects they are classified as a therapeutic group⁴. By contrast, there is no such term for ADRs. It is usually assumed that a group of drugs with a similar therapeutic effect profile will have a corresponding ADR profile as well.

Nevertheless, ADRs are categorized in several ways. Scientists or organizations use their own vocabularies to describe ADRs. These are sometimes more comparable to disease classifications than to therapeutic classifications. The categorization used for ADRs each serve their own goal. The categorization can contribute to the recognition of ADRs, or to therapeutic decision-making [Karch 1975, Leufkens 1995, Modell 1961, Peny 1994]. Some of the commonly used categorizations will be briefly described in order to give an impression of the variety of information that ADRs can represent.

Qualifications of Adverse Drug Reactions

Category: Pharmacological profile

One categorization is to discriminate between ADRs that are part of the pharmacological profile of a drug, and those ADRs that are not [Davies 1977]. Furthermore, an ADR can be part of the pharmacological profile of a drug in two ways. Firstly it can be too much of the desired pharmacological effect: for instance, a hypertensive patient becomes hypotensive. Secondly it can be an effect caused by the same mechanisms as the therapeutic effect, but at another site in the body: for example, beta-blockers (in principle) have an effect on all beta-receptors in the human body, or at least on beta receptors in various tissues and organs. Some of these effects can be used in a therapeutic way, such as for an antihypertensive effect. Other effects, such as cold fingers or slowness of movement, are deemed ADRs. Effects that are not an intrinsic part of the pharmacological profile are effects such as idiosyncrasy, secondary effects, intolerance, and immunological reactions. A distinction between these different kinds of effects helps physicians to assess drug profiles from the same therapeutic group.

Category: Type-A or Type-B

A comparable set of terms is the use of Type A and Type B adverse drug reactions [Rawlins 1977]. Type A represents 'augmented ADRs' that can be directly derived from the pharmacological profile. An example of this are the toxic effects of cytostatic drugs, which inhibit the growth of all rapidly-dividing cells in the body: they not only destroy the cancer cell, but the bone marrow cells as well. Type B ADRs are 'atypical ADRs' which cannot be simply derived from the pharmacological profile. An example of this is the anaphylaxis caused by the analgesic drug glafenine.

Category: Predictability

Another distinction can be drawn, that between 'predictable' and 'unpredictable' ADRs [Rawlins 1977]. Predictable ADRs are often part of the pharmacological profile of the drug. Unpredictable ADRs include unexpected immunological and allergic reactions. However, the above-mentioned classifications are not exclusive. A situation can exist in which the pharmacological adverse effect of the drug was unrelated to the known effects within the time constraint defined by the treatment regimen, and could therefore not be predicted. An example of this is the cough caused by angiotensin-converting enzyme inhibitors. The opposite situation is an immunological or allergic adverse reaction that could be predicted because of chemical similarities to other drugs, for example the allergic reactions to certain penicillins and cephalosporins. See Table 1.

Table 1: Four types of Adverse Drug Reactions

ADRs	Predictable	Unpredictable
Related to pharmacological profile	Beta-blockers and slowness	ACE-Inhibitor and cough
Not related to pharmacological profile	Cephalosporin and anaphylactic shock	ACE-Inhibitors and angioedema

Category: Action

In this category three types of actions are distinguished: drug-actions, patient-actions and inter-actions [Meyboom 1991]. The ADRs are classified according to their cause. Drug-actions can be explained by some property of the drug (including the dose), patient-actions are the collected immuno-allergic, very seldom (unexplained), or subpopulation-specific actions. The last category, the inter-actions, are all effects caused by combinations of substances, which can be drug or food (including alcohol and tobacco) or others. The use of this

³The concept 'profile' [Vos 1991] can be used by scientists to list a group of characteristics of a drug in such a way that they can be easily compared with familiar drugs. A disease profile can also be constructed. The latter profile is expressed in terms of 'wished for' actions: actions believed to have a positive effect on the disease. Combining the profiles of a certain drug with that of the disease profile can result in a profile showing the operationalized actions and the as yet unmet therapeutic actions of a drug. ADRs complicate this picture by introducing unwanted or noxious actions. The introduction of co-morbidities would be a further step in modelling the complexity of treatment with drugs.

⁴Categorization into therapeutic groups has proved to be useful. Pharmaceutical industries often use this technique to organize their research and development departments [Spilker 1989].

category is to introduce explanations of ADRs.

Category: Organ

In books of reference the ADRs are often assigned to the affected organ [Koning 1996]. This categorization makes it easy for physicians to pay special attention to a certain organ or symptom. They can also rapidly check if there are drugs that are known to cause this organ-specific symptom.

Besides the classification of ADRs there are more aspects that complicate this matter. Some examples are mentioned in the following paragraphs:

Certainty of the information:

Before describing the ADR profile of a drug, it must be firmly established how certain it is that the observed event really is caused by the drug. Several kinds of algorithms are used to define the (causal) relation between the adverse event and the drug [Karch 1975, Larson 1993, Riezebos 1989]. These algorithms are mainly used for the analysis of data collected in a spontaneous reporting systems. Each individual case, however, must be analyzed.

Quantification of Adverse Drug Reactions:

The aspects of ADRs discussed so far are all qualitative. Another aspect is the incidence of the ADRs. If feasible, it is important to establish how often a certain ADR is observed in a population of drug users. Scientists and physicians want to be able to predict the likelihood that an individual patient will develop a certain ADR. In order to calculate the incidence of an ADR in relation to the individual risk, data are collected from large populations with regard to both drug use and ADRs. Several methods exist to perform such studies and are part of the field of pharmacoepidemiology [Leufkens 1994a, 1994b, Loonen 1989, Petri 1989, Stolley 1982, 1995, Strom 1994c, 1994d, Wallander 1993, Waller 1992, Whitmarsch 1993]. These methods differ in the type of data collected, the way the data are collected, and the time period over which the data are collected. The time period may refer to the phase of drug development, for instance before or after registration [Hanssen 1989]. It is important to define this time period because it is often the case that the more a drug is used, the more its ADRs become known. For this reason new drugs are sometimes, entirely unjustifiably, preferred over older ones.

Natural disease versus artificial disease:

A complication for collecting data on the incidence of an ADR is that some ADRs can take the form of a natural disease. For example, in Figure 3 an ADR of drug X is effect Y, which is also a naturally occurring disease. To distinguish between the natural disease and the ADR, the incidence of the effect can be compared in a population of users and a population of non-users.

Contra-indication:

A final aspect of ADRs that deserves mention here is that certain ADRs remain undetected because patients at risk of developing an ADR are excluded from the user population. This is what medical doctors do when they formulate a contra-indication. By formulating contra-indications to a drug, a selective group of patients is excluded from drug treatment in order to prevent the development of the particular ADR. In this context the difference between relative and absolute contra-indications refers to the severity and certainty of the effect. An example is that patients suffering from diabetes mellitus are usually not given beta-blockers to treat hypertension, because beta-blockers increase sugar intolerance.⁵

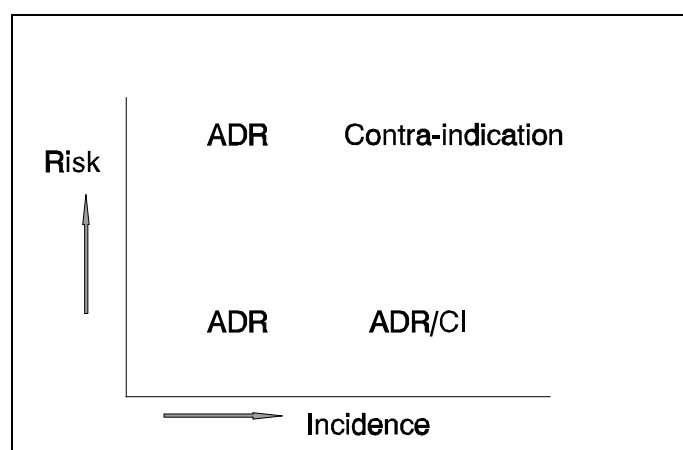

Figure 2: Risk and incidence in a graph

The combination of high risk and low incidence is termed an ADR. High risk / high incidence (in a subpopulation) is a contra-indication. Low risk / low incidence is an ADR. Low risk / high incidence can either be an ADR or a contra-indication. With regard to the pharmacological sciences, one typical aspect should be added: the concept of the Structure Activity Relationship (SAR). This concept is used to define the relation between the chemical structure of a drug and its effects. Certain functional groups or parts of a molecule are crucial elements determining the pharmacological effect, but can also be associated with certain ADRs. This is important knowledge for medical chemists and comprises one of the leads in the development of new chemical entities. The aspects of ADRs described so far are meant to give a rough sketch of the meaning of ADRs in medical practice and pharmaceutical research. However,

⁵It might be possible to reformulate 'contra-indication' and define it as another variable. In contrast to the drug-centred term contra-indication, a more patient-oriented concept could be employed. Whereas a contra-indication is meant to exclude specific patients from the use of a drug, a patient-oriented approach would be to match the complete profile of diseases and disorders of a patient with existing pharmacological profiles. This approach could be useful to match the wished-for patient profile with the available pharmacological profiles, especially for patients with co-morbidities. Pharmacological ADRs could then be considered in the same way as therapeutic effects, because together they represent the pharmacological profile.

an ADR can also be described in terms of useful information that can be used in the process of drug design and development: the unwanted part of the drug action is made accessible and functional. Although the major difference between the knowledge of therapeutic effects and ADRs is that the former is related to an intended aspect and the latter is not apparently intended, they can both have a function in research on drugs and may also contribute to the proper practical use of drugs.

Concepts and definitions of Adverse Drug Reactions

We postulate that a systematic collection and description of data on adverse drug reactions is an essential part of a better understanding of drug actions and use. In order to properly categorize and apply this knowledge, definitions and standardized methodologies should preferably be used.

It is evident that collecting ADR data is not the primary aim in drug research and development. Still, scientists do focus on the balance between the efficacy and safety of drugs and consequently this type of knowledge is essential to define the therapeutic profile of drugs. Specific knowledge on ADRs can, in principle, be built up at the same time as the knowledge on therapeutic effects is gathered. In both types of knowledge the scale can go from individual, or local knowledge to population-based, or generally accepted knowledge. Individual and local knowledge is often represented by case reports. The description of an individual patient, using one or more drugs, can include observations of unwanted or unexpected effects. However, the implications of this knowledge are uncertain until more case reports with the same observation are reported. The implications are accorded even more substance if (patho)physiological explanation can be given.

In his guide to clinical trials Spilker [1991] writes about the case report as having 'a valuable function by alerting the medical community to potentially important adverse reactions and previously unknown therapeutic benefits of a medicine.' However, the definitions of an adverse drug reaction can widely vary since they can be used for quite different purposes. An institute like the World Health Organization [Anonymous 1970, 1994] uses a very general and broadly interpretable definition:

'An adverse drug reaction is any response to a drug that is noxious and unintended and that occurs at doses used in man for prophylaxis, diagnosis, or therapy.'

This definition can be used as an umbrella definition for all effects caused by a drug that are not wanted or are unexpected in normal therapy. Its interpretation, however, can differ substantially. For example, it is debated whether drug abuse or addiction are included in the definition. The exact meaning of the definition is therefore a matter of scientific and social debate.

The more specific a definition is made, the more it tends to be related to a specific situation, excluding certain elements present in other situations. The definition may also depend on the way the information will be further used. Some of the terms used for ADRs have a slightly different meaning in different contexts: side effect, adverse drug reaction, adverse effect, toxicity, idiosyncrasy, adverse (clinical) event, adverse reaction, and adverse event, among others. Institutes and registration authorities such as the WHO, CIOMS, FDA, International Federation of Pharmaceutical Manufacturers' Association (IFPMA), BBG etc, have made attempts to make definitions more unambiguous [Anonymous 1994, CIOMS 1990, Venulet 1993]. An example of this is that the use of the term 'side effect' is strongly discouraged. The Federal register [1993] puts it thus:

'The old term "side effect" has been used in various ways in the past, usually to describe negative (unfavourable) effects. It is recommended that this term no longer be used and particularly should not be regarded as synonymous with an adverse event or adverse reaction.'

However, a glimpse at recent medical literature shows that this term is still frequently used. Part of the confusion about this term is due to the implicit assumption that a side effect is part of the pharmacological profile of a drug. Furthermore, in many cases it is simply unknown whether or not an ADR is part of the pharmacological profile.⁶ The definition an author implicitly uses can sometimes be derived from the text itself.⁷

The role of definitions to standardize particular observations ought to be complemented by the use of standardized methods to collect

⁶ Type A and Type B classification [Davies 1977].

This classification distinguishes between predictable pharmacological reactions (type A-augmented) and unpredictable idiosyncratic reactions (type B-bizarre).

Quote: *'Unfortunately, most collected information on ADRs ignores this classification or does not provide the necessary detail to allow this derivation.'*

This makes this classification into a mainly theoretical and abstract one. For practical use of the definition, a third category has immediately to be introduced; Mechanism Unknown.

For practical use the Type A/ Type B separation is further specified with regard to the level on which the ADR is manifested.

For 'type A' (augmented) the subcategories are: Pharmaceutical causes (refers to factors that determine pharmaceutical and bioavailability), Pharmacokinetic causes (factors that cause abnormalities in drug absorption, drug distribution, drug elimination), Pharmacodynamic causes (drug receptors, homeostatic mechanisms, or disease factors that influence the drug).

'Type B' (bizarre) subcategories are: Pharmaceutical causes (for instance, the eosinophilia-myalgia syndrome and L-tryptophan, nebulizer solutions and paradoxical bronchoconstriction), Pharmacokinetic causes, and Pharmacodynamic causes (genetic causes of abnormal response, immunological reasons for abnormal response, neoplastic and teratological reasons for abnormal response).

⁷Examples of indirect definitions of ADRs.

The definitions in Sneader [1986] can be found in two chapters entitled 'Drug toxicity' and 'Allergic reactions to drugs'. The terminology used in this book is as follows (although the terms are not presented explicitly as definitions):

* Adverse drug reactions can be caused by direct damage to tissues by exposure to excessive amounts of the drug or indirectly by allergic phenomena.

* Toxicity may be remedied by dosage adjustment.

* Allergic hypersensitivity requires withdrawal of the offending agent.

* A side effect is an inevitable consequence of the pharmacological action when normal doses are administered.

* Secondary effects are those which arise from functional changes induced by drug therapy.

data on ADRs. Such methods, together with the definitions, are the conceptual tools that can be used in the pharmaceutical and medical sciences to express existing and new knowledge about ADRs, and are therefore part of the total drug profile.

Adverse Drug Reactions and their medical context

A drug is usually given to a patient in order to treat a disease. The disease is referred to as the indication for that particular drug. The use of the term 'indication' generally implies that the drug is given to the patient in order to induce a specific effect. The 'therapeutic' effect is the effect expected or intended to occur following the correct administration of the drug.

A very central feature of ADRs can now be established: they are context-dependent.

For disease A, effect X is the therapeutic effect (e.g. atropine as a mydriaticum). For disease B, effect Y is the therapeutic effect (e.g. atropine as a spasmolyticum). An effect of the drug that is not wanted in the treatment of the disease is considered to be an ADR. In this example, the disease is the context within which the therapeutic and adverse effects are interpreted. Especially those ADRs that are part of the pharmacological profile of the drug can be subject to different interpretations.

The context of a drug and its effects can, apart from the disease in question, be extended to include patient characteristics⁸, knowledge about possible actions of the drug, and population characteristics. All of these aspects can determine the meaning of an observed effect and label the effect as an ADR.

The assessment of an ADR is also context-dependent. For instance, an ADR can be unwanted or wanted. An example in which an ADR plays a useful role is the use of promethazine for anti-allergic purposes: promethazine is sometimes prescribed to patients who suffer from allergic reactions because it is an antihistaminic drug and it also exhibits a favourable additional effect: sedation. The main effect of the drug is to suppress the allergic reaction, but the sedative effect is considered to be additionally beneficial for the well-being of the patient, since it supports an undisturbed night's rest. However, this ADR is much less favourable if the patient uses the drug during the daytime and has to be alert, because of their job or for car driving.

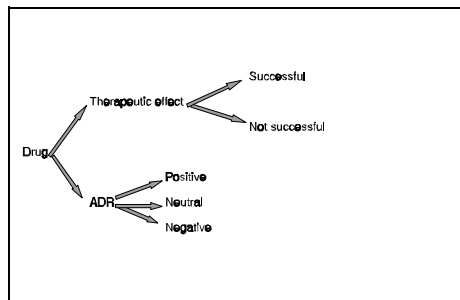

Figure 4: Differentiation of types of effects of a drug

The difference in the appreciation of therapeutic effects and ADRs is that the therapeutic effects are related to the therapeutic intentions, and can therefore either be successful or not. By contrast, ADRs are judged in relation to the patient's whole situation and to the extent that they are harmful. The therapeutic effect, therefore, is directly related to the disease of the patient; the ADR can either be directly related to the patient's disease (positively judged ADR), or more indirectly to the patient's overall situation (risk-benefit ratio).

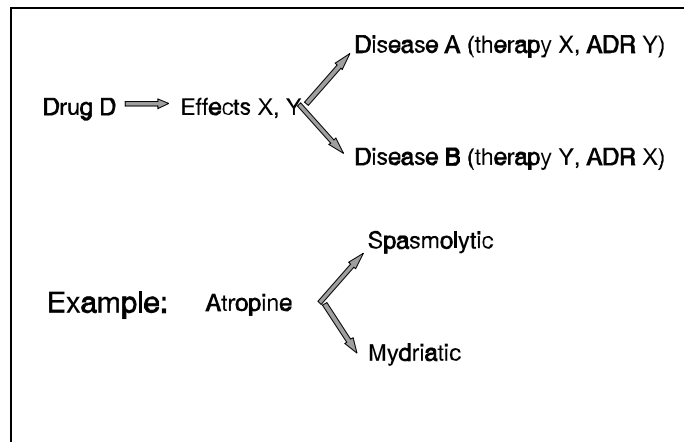

Figure 3: Two effects, two different contexts

The functional context-dependency of an ADR can also be illustrated with another example: two drugs, C and D, both have the same effect in patients: they lower their blood pressure. Drug C is given to hypertensive patients, and the intended effect is to get normotensive levels. Drug D is given to normotensive, rheumatoid patients and the intended effect is to relieve the rheumatoid symptoms. The effect of lowering the blood pressure in relation to drug C is a therapeutic effect, while in relation to drug D it is an ADR. However, without the context of the patients' disease, it would be impossible to label the blood pressure lowering effect as either therapeutic or an ADR.

There are of course ADRs for which this context dependency is less obvious, or even irrelevant. An anaphylactic shock will never be an effect that can be associated with some sort of treatment. There can be a relation between the effect and the disease which is context-dependent. For instance, the incidence of the ADR effect of a drug can vary between different patient populations.

⁸The process of channeling can be described as an interaction between drug characteristics and patient characteristics [Petri 1991a, 1991b]. Some effects, being therapeutically desirable or unwanted, will be more emphasized in certain patients. This can result in the suggestion of two drugs having different pharmacological profiles. One drug seems preferable to the other, while on closer inspection the difference can be explained on basis of the population characteristics of the two groups of patients receiving the drug. The population characteristics can be a predictor for the probability that an event will occur (a patient with a concurrent disease is more likely to develop an ADR).

Channeling can be defined as the process of how (on the basis of claims) the use of a drug is directed towards subpopulations. This is an explicit interaction between pharmacological knowledge and a social process of expectation and promise.

In conclusion: knowledge about an ADR can only be properly expressed in relation to the drug and the disease and/or the characteristics of the patient. Without this information it is not possible to claim that a certain effect is beneficial or is an ADR.

Context-dependency of Adverse Drug Reactions

One effect of a drug can also have more than one meaning if more fields of research are concerned; in each separate field of research the effect may represent a different kind of knowledge. In one field of research the effect is an ADR, but in another field it can be a useful property.

The exploration of the combined knowledge derived from different contexts (research areas) can lead to new and useful information. This is especially because of the fact that effects deemed an ADR in one context can have a different role in another context. One very well known example of this is the therapeutic use of the drug minoxidil. The drug, which is usually given to hypertensive patients, causes an antihypertensive effect but at the same time may stimulate hair growth. The latter effect maybe an unwanted ADR, especially for women. However, in the context of cosmetics, stimulating hair growth may be an attractive and most desirable effect. Clearly, baldness and hypertension are not closely related disorders from a medical point of view. The finding of an alternative indication of minoxidil was largely due to the fact that hair growth is an easily recognized effect. The potential use of this effect was also stimulated because of the failure of other treatments for this condition so far. Although not all cases will be as logical as that of minoxidil, it is in this contextual shift that the potential of ADRs to be a source of new information lies.

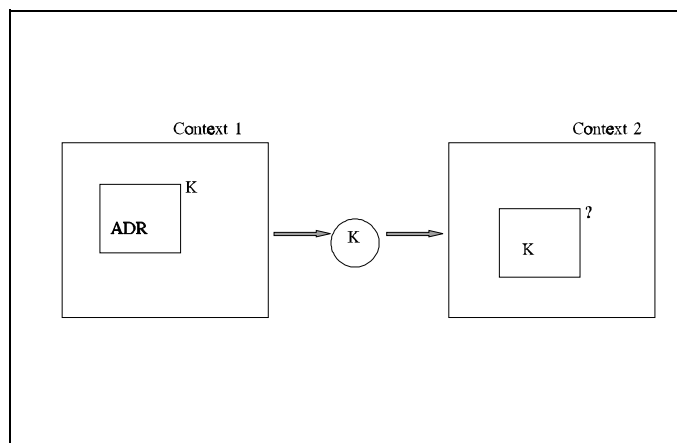

Figure 5: Schematical representation of knowledge transfer

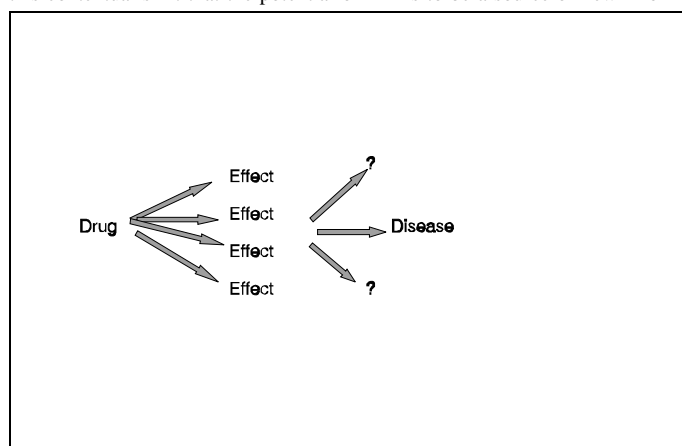

Figure 6: Profile of a drug

Of all the different effects caused by a drug, it is usually one and sometimes two which represent its intended effects. All the additional effects, that are commonly ADRs, can have interesting meanings within other contexts. However, such relations will not always be explored because the ADRs are observed in the context of the primary disease being treated, while their potential use usually lies beyond this specific context. Medical sciences are often organized in pathophysiologically-oriented groups: organ-related diseases occupy centre stage. The potential use of an ADR therefore tends to be limited by the narrow context in which it is generally seen.

Adverse Drug Reaction as a carrier of information.

ADRs are a peculiar form of medical knowledge: they are part of the effects that appear in combination with the therapeutic use of a drug. The ADRs can be

unwanted, noxious, unexpected or unintended. One of the major purposes for collecting data about ADRs is that this information can be used to estimate and weigh the risks of drug use for an individual patient or a population of patients. The clinical or physiological reactions (adverse clinical events) that are called ADRs, or are labelled as such, can be effects or symptoms that have no relation at all to the disease for which the patient is being treated. Isolated from the context of the disease and the patient, these effects could even belong to a medical discipline different from the one in which they were initially observed. A group of similar ADRs can be caused by a group of completely different drugs, or a group of very similar drugs can cause a range of ADRs that are related to different medical disciplines. The consequence is that the ADR phenomenon almost always touches more than one medical discipline or medical context. However, the ADR is often not the central topic of medical activities, but is only of interest in relation the treatment of the disease, the risk to the patient, possible alternative treatments, or the establishment of the certainty of the observed effect. Attention to ADRs is focused to those aspects that are necessary to evaluate how important the influence of the ADR is on the success of medical treatment of diseases and for the well-being of the patient.

The concept of ADR is not bound to a specific discipline in the medical sciences. Except for special institutes that exist only in order to collect data on ADRs, there is no medical discipline in which ADRs are a central issue of research (although the collection and interpretation of ADR-data is one of the central objectives of pharmaco-epidemiology). Knowledge of and research into ADRs is both specific (local) and general (global). At the local level, the question addressed is the association of a drug, used for a specific indication, with the observation of one or more ADRs. This knowledge usually remains within the particular discipline, unless the drug is used for other diseases. The knowledge is locally used for the balanced treatment of patients.

Global knowledge of ADRs can be used as an auxiliary tool for the establishment of certainty, with regard to the incidence and severity

of the ADR in the estimation of risks, or to determine the direction in which research or treatment should be continued. Global knowledge of ADRs is partly incorporated into subdisciplines such as pharmacoepidemiology or post-marketing surveillance research. Knowledge of ADRs that can be situated between local and global knowledge consists of more or less structured knowledge related to such subjects as action mechanisms, ADR categorization, and general risk estimation. This kind of knowledge can be found in all medical disciplines relating to the use of drugs and patient care.⁹

An important aspect of ADR-related knowledge is that it is founded in medical practice; without patients no ADRs can be observed. It is also knowledge which is difficult to express in abstract terms. The knowledge can easily be re-used in the medical practice from which it originated without extensive theoretical reflection.

The outcomes of the more theoretically founded research in subdisciplines are often used to compile handbooks or review articles on drugs. The construction used to represent the information might be: Using drug X in population P with attribute Y produces a likelihood Z that ADR A will occur. This knowledge is then represented in such a way that it is as applicable as possible to the situation of an individual patient.

Example of communication about Adverse Drug Reactions:

Observations from medical practice are accumulated in a knowledge collection, using standardized methodologies where possible. This knowledge is then directly accessible for practical use, such as the better weighting of therapeutic decisions. The knowledge follows a very short communication line: physician - collection point - physician.

In general, knowledge about ADRs is only linked back to medical practice; only incidentally is a relation to medical research found. The representation of data on ADRs in handbooks and articles in medical practice can be seen as the common use of information about ADRs.

However, a problem is that researchers use the ADR concept only in relation to the context of disease, patients and treatment. Only when these variables are set is it meaningful to introduce the term ADR. In fundamental research, whether it is physiological, pathological, chemical, or pharmacological, there is no place for a term like ADR because not all of the mentioned variables are set (the use of the concept ADR demands a patient and a disease, otherwise the effects will be described more neutrally). This makes communication about ADRs between practice and fundamental research difficult. The ADR has been translated into terms that are imbedded in this research.

The role of Adverse Drug Reaction as trigger of new information:

Despite the fact that there is no structural research into the stimulating role that ADRs can play in medical research, many anecdotes and examples can be found in which such a role is described. The general term under which these anecdotes are given is often 'clinical serendipity'. In contrast to the pattern of direct feedback of the knowledge on ADRs to medical practice, in the clinical serendipity

⁹The concept of a 'boundary object' can be used to describe the global and local roles of ADRs in and through medical and pharmaceutical disciplines.

A boundary object can be described as follows:

- It is at the same time concrete and abstract, specific and general, conventional and customized.
- It is flexible enough to fit in local situations and robust enough to retain its identity.

The boundary object is a concept that can be used in more than one context, and which can be used for communication between contexts.

The concept of 'standardized packages' can be used for the description of standardized methodologies used for the collection, interpretation, and presentation of ADR data.

An interpretation of ADRs by means of Boundary Objects and Standardized Packages.

Quotation from Fujimura [1992]:

'..used by researchers to define a conceptual and technical work space which is less abstract, less ill-structured, less ambiguous, and less amorphous'.

The concepts of 'boundary object' and 'standardized packages' are a continuation (and critique) of the translation concept as introduced and explained by Latour and Callon [Callon 1983, 1985, Latour 1987]. The major critique of Star, Griesemer [1989] and Fujimura [1992] is that the translation (and related enrolment, obligatory points of passage) concept does not leave space for the description of independently and equally acting actors. In other words, translation is a game with only one winner, and standardized packages and boundary objects are part of a game with as many 'winners' as players.

The above-mentioned examples of terminology, definitions and research tools can be interpreted as the boundary objects and standardized packages of medical and pharmaceutical sciences. They make it possible that an ADR is a concept that crosses the borders between different disciplines. The process of stabilization and the attempt to come to a consensus on the terminological and methodological aspects are part of the communication process between those involved in needing and using the concept of the ADR.

The same argument can be made for the concept of PMS which is recognized by actors in the field [Koning 1996]; they describe the term as a repertory term. They call it *smeerolie* - literally, 'lubricant'.

scenario ADR-related knowledge is manipulated at another level before being fed back into medical practice¹⁰.

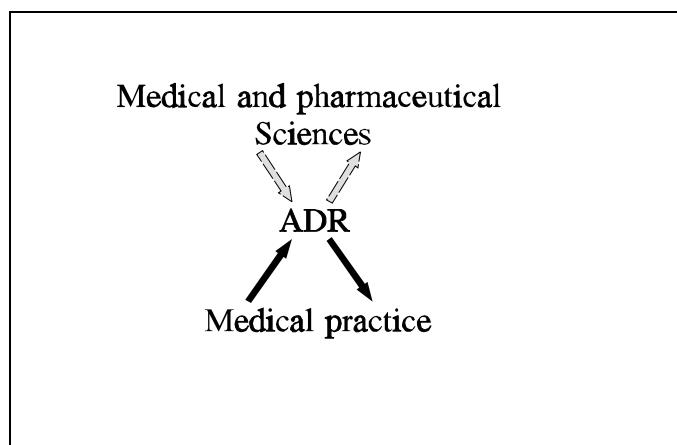

Figure 7: Feedback structures of adverse drug reactions

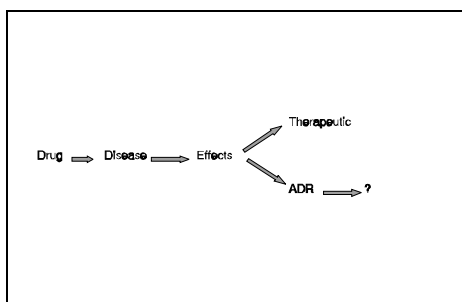

Figure 8: Unknown possibilities for adverse drug reactions

A relevant quotation from Spilker [1989] in this respect is:

*'Adverse reactions for one use of a drug may serve as a new indication for the same drug. For example, a drug that is found to cause constipation as an adverse reaction (e.g. morphine) may be used as an active antidiarrhoeal. A drug that causes sedation (e.g. certain antihistamines) may be used as a sleep-promoting agent. Adverse reactions also stimulate companies to search for chemically related compounds that have more potent actions of the desired type. A well-known example of this situation relates to the sulfonamide antibacterial drugs. It was noticed that *æ*sulfa \AA drugs lowered blood sugar and caused diuresis (excessive urination) as adverse reactions. Many new compounds were synthesized over many years in an attempt to exploit these adverse reactions.*

Eventually, the oral antidiabetic drugs (sulfonylureas) were discovered.'

Other examples are Clonidine (from the treatment of swollen nasal mucosa to antihypertensive drug) and Aspirin (from painkiller to use in stroke prevention) [Blumenthal 1989, Roberts 1989].

The examples mentioned above have one aspect in common: an ADR of an existing drug, or a drug under development, is recognized as an effect that could be of therapeutic interest for another indication than the original indication. Sometimes the drug continues to be used for both indications, but in other cases the new indication became the only one. This, in fact, is the result of the feedback of clinical, therapeutic observations.

The same pattern can be recognized in all these examples. A drug has an ADR that is part of the pharmacological profile and this ADR is a therapeutic effect when the same drug is administered to patient with another disease. Sometimes the particular ADR is known from the start of the development of a certain drug. In other cases the ADR can be anticipated from knowledge of the pharmacological profile of the drug. Alternatively, the ADR might have been found only after the drug was introduced onto the market and used in larger patient populations.

'Changing' the ADR into a therapeutic effect is therefore a very straightforward process. More complicated developments following the observation of an ADR are also possible.

Knowledge of an ADR can provide new information or confirm existing information about activities related to certain chemical groups or compounds (structure-activity relationships). The ADR can give rise to either the elimination of the part of the molecule causing the ADR or a change in the molecule such that the ADR becomes stronger and can be used therapeutically for another disease.

Current literature on drug discovery [Spilker 1989, US congress 1993, Blumenthal 1989] does mention ADR triggers in obtaining new indications for a drug, although this is not described as a structural innovation technique.

In Chapter 3 (How adverse drug reaction can play a role in innovative research - Similarities in ADR profiles of Captopril and Penicillamine) we argue that the observation of ADRs can contribute structurally towards the process of drug innovation. The theoretical model introduced in this chapter is illustrated with historical examples from the history of Captopril.

Adverse Drug Reactions as a trigger for innovative developments.

The role that ADRs can play in the process of drug design and development is recognized in the present literature. However, hardly any

¹⁰ The commercial exploitation of a second indication of a drug is limited by the length of patent protection and the possibility of extending the period of patent protection with a new claim for the use of a drug [Nieuwenhoeven Helbach 1992, Huydecoper 1992].

attempts have been made to model this role so that the ADR becomes part of a structural strategy for drug innovation. Because ADRs are as essential a part of the drug profile as its clinical application, and because these aspects are related to several types of knowledge, it seems fruitful to explore the pathways which can be used to make the contribution of ADRs to innovation more visible and influential.

The following basic elements and assumptions for a model on the role of ADRs in innovative research can be mentioned:

-There is knowledge related to ADRs which is not extensively explored in spite of the fact that it can contribute to progress in medical and pharmaceutical sciences. Knowledge related to ADRs can be divided into three major pathways of innovation: chemical, (patho)physiological, and therapeutic. All three can be employed in order to feed ADR knowledge back into the more fundamental sciences.

-Effects that are labelled 'ADR' in one medical context (where context is defined by disease and patient type) can be of an entirely different nature in another context. Because of the diversity and specialization of the medical and pharmaceutical sciences, knowledge from one context is not necessarily translated into another. Yet the combination or linkage of knowledge from two separated contexts might lead to new and useful knowledge, which can be used either directly or indirectly.

-Knowledge on ADRs can be found in scientific articles. Although ADRs are not always explicitly named in texts, the combination of a fixed set of articles and relevant expert knowledge on the topic can provide a suitable database for exploration.

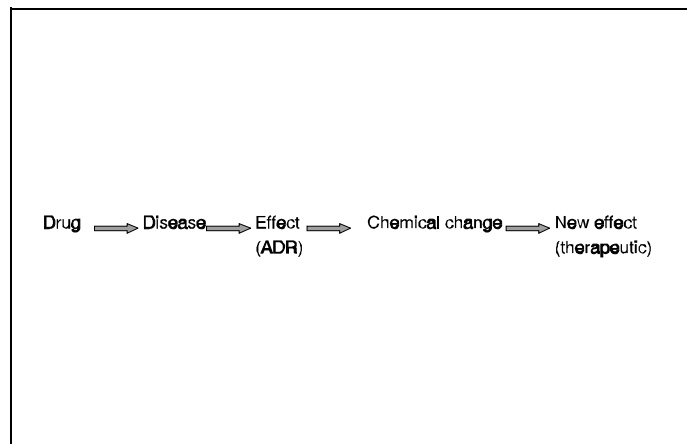

Figure 9: One pathway of innovation